

REV	DESCRIPTION	Date	APPROVED
A	PRODUCTION RELEASE	10/25/99	

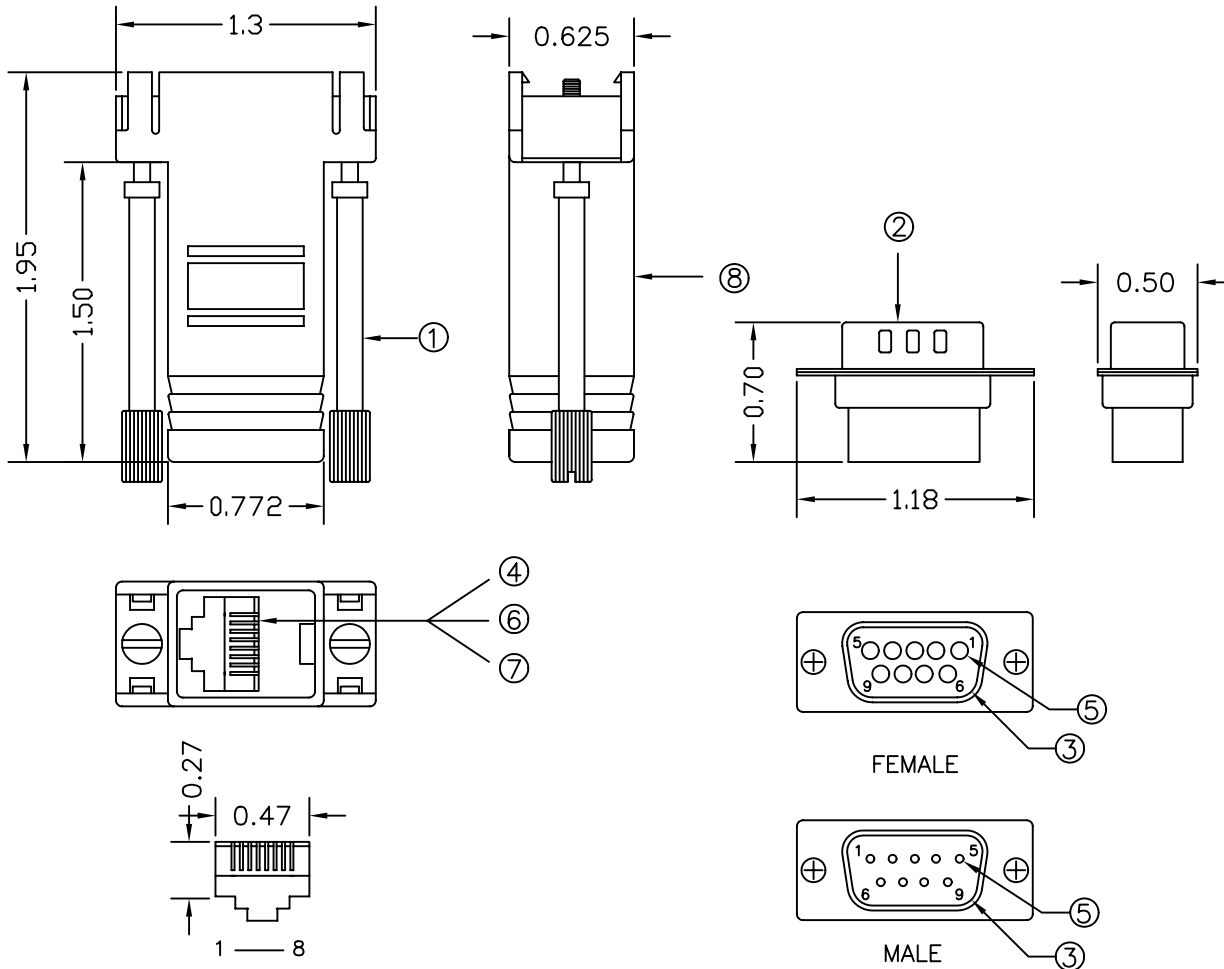

WIRING DIAGRAM :

8 CONDUCTORS	
PIN 1	BLUE
PIN 2	ORANGE
PIN 3	BLACK
PIN 4	RED
PIN 5	GREEN
PIN 6	YELLOW
PIN 7	BROWN
PIN 8	WHITE

1	SCREW: THUMB SCREW TYPE
2	SHELL: LOW CARBON STEEL
3	HOUSING: ABS UL94V-0
4	INSERT: ABS UL94V-0
5	CRIMP TERMINAL: PHOSPHOR BRONZE 50u" HARD GOLD PLATING OVER 100u" NICKEL
6	SPRING WIRE: PHOSPHOR BRONZE 50u" HARD GOLD PLATING OVER 100u" NICKEL
7	LEAD WIRE: BRASS
8	HOOD: ABS UL94V-0

ITEM NUMBERS
GCDB09TF8C
GCDB09TM8C

UNLESS OTHERWISE SPECIFIED DIMENSION TOLERANCES ARE		CABLESYS		14700 E ALONDRA BLVD, LA MIRADA, CA 90638		WWW.CABLESYS.COM	
DECIMALS		ANGULAR		DB9 TO 8P8C JACK MODULAR ADAPTER			
.X +/- .050		+/- 0.5		DESIGNER	T.L.	SIZE	A
.XX +/- .010				DRAFTSMAN	I.C.	UNIT	MM
.XXX +/- .005				APPROVED BY		SCALE	NTS
DO NOT SCALE DRAWING				FILE NO.	ACCESSORY\GCDB09X8C		REV. A
				PAGE NO.	1/1		ITEM NO. GCDB09TX8C
				DATE	10/25/99		DWG NO. DB09TX8C

Approved by: _____ Title: _____ Date: _____